

MOTCON *Lite*

WIRELESS AUTOMATIC WATER LEVEL CONTROLLER

Saron

Innovature labs

Installation manual

(for Single phase motor starter only)

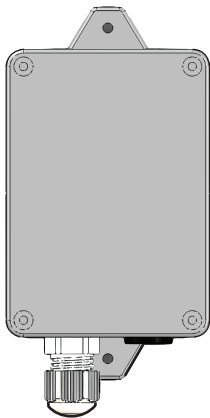
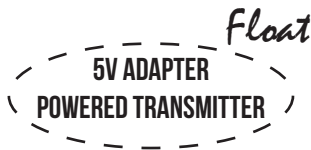

Read this manual carefully before any operation.

Keep this manual for future use

Important

Before installing and operating this device, read & study this manual thoroughly. Proper installation is essential for safe operation of the device.

Transmitter functional diagram.

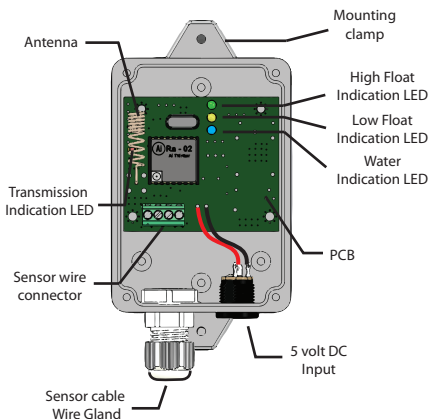

Receiver functional diagram.

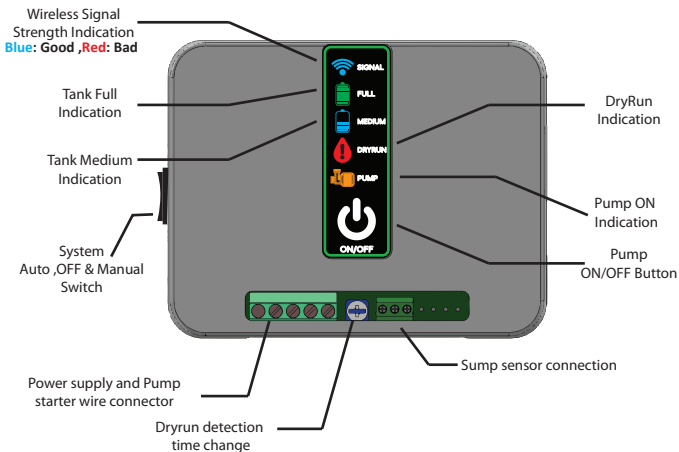

Transmitter sensor wiring diagram with over head tank only. (for open well / bore well users)

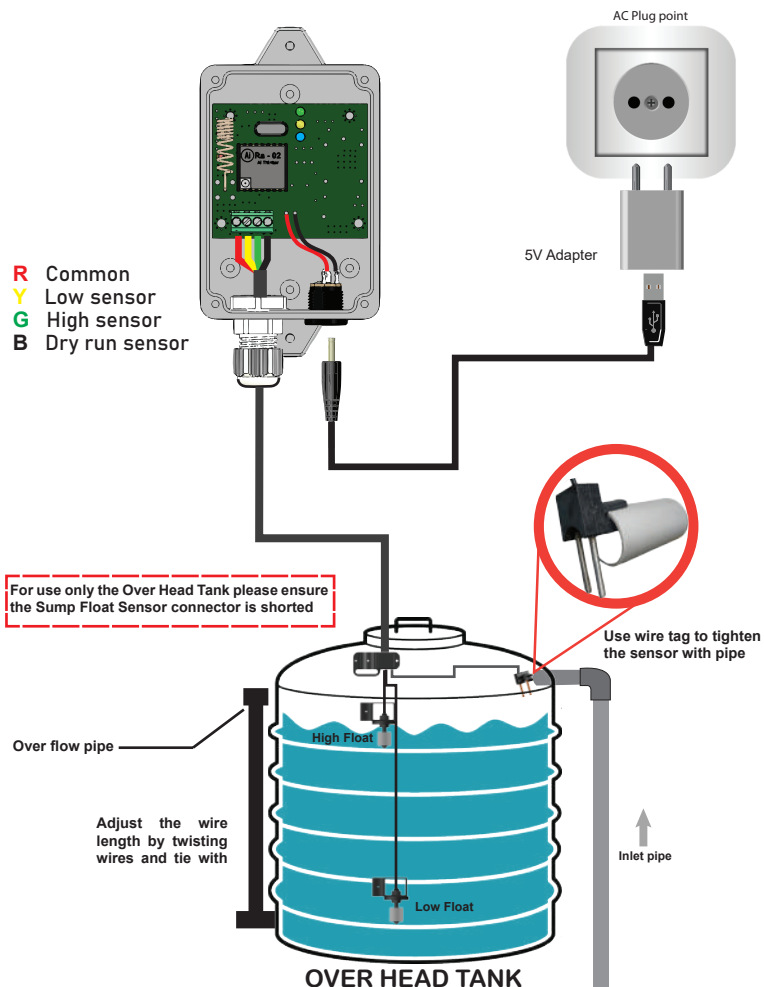

**Sensor wiring diagram with sump storage only.
(for under ground storage users)**

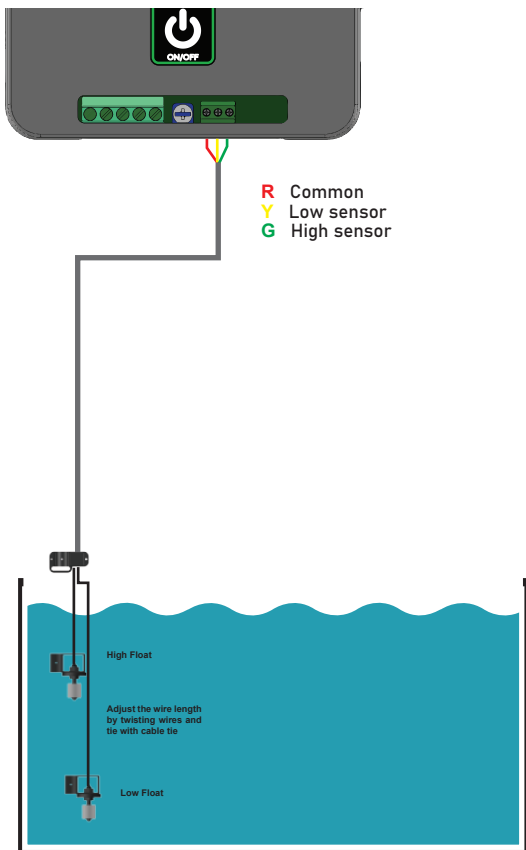

SUMP TANK(under ground storage)

1. Singlephase Submersible Pump Starter with Running capacitor only

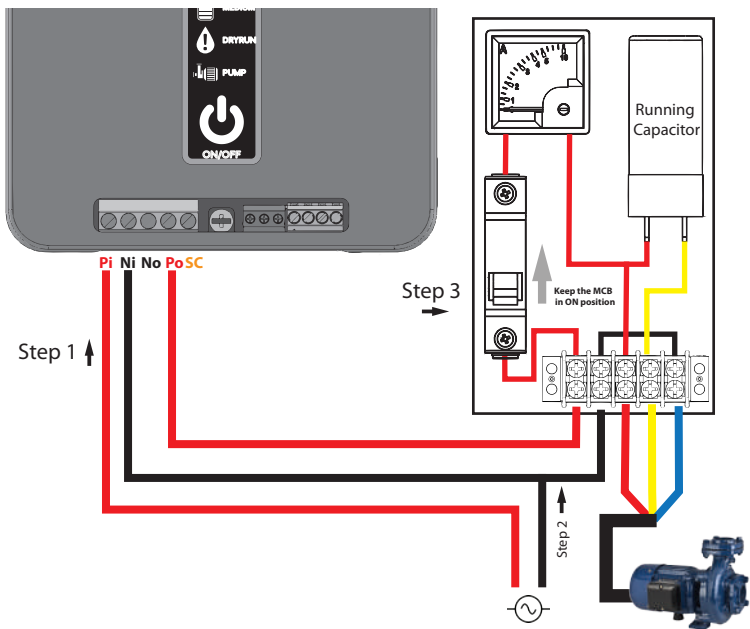

- Step 1 Remove the Phase from the pump starter panel and connect to Phase input of Motcon Lite connector **Pi** and connect phase output **Po** to phase input of pump starter.
- Step 2 Connect the Neutral **Ni** input as common to both Motcon Lite Controller and starter panel.
- Step 3 Keep the MCB in "ON" (up) position always.

2. Non contactor type single phase Submersible pump starter with starting and running capacitor (openwell / borewell).

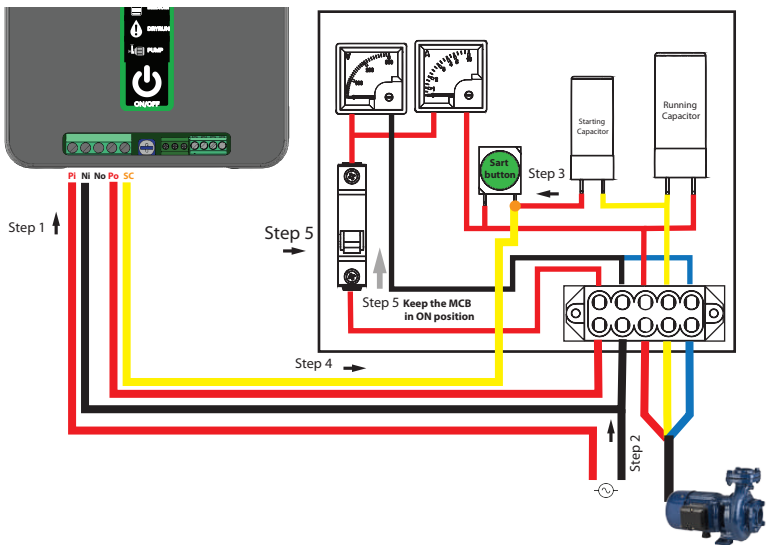

- Step 1 Remove the Phase from the pump starter panel and connect to Phase input of Motcon Lite connector **Pi** and connect phase output **Po** to phase input of pump starter.
- Step 2 Connect the Neutral **Ni** input as common to both Motcon Lite Controller and starter panel.
- Step 3 Identify the Starting capacitor wire in "Push ON" Green button of starter panel, using with colour code to the starting capacitor.
- Step 4 Connect the SC terminal of Motcon Lite pump controller to the terminal of "Start ON" green button where the starting capacitor wire is connected.
- Step 5 Keep the MCB in "ON" (up) position always.

3. Contactor type Single phase submersible pump starter with starting & running capacitor (openwell / borewell).

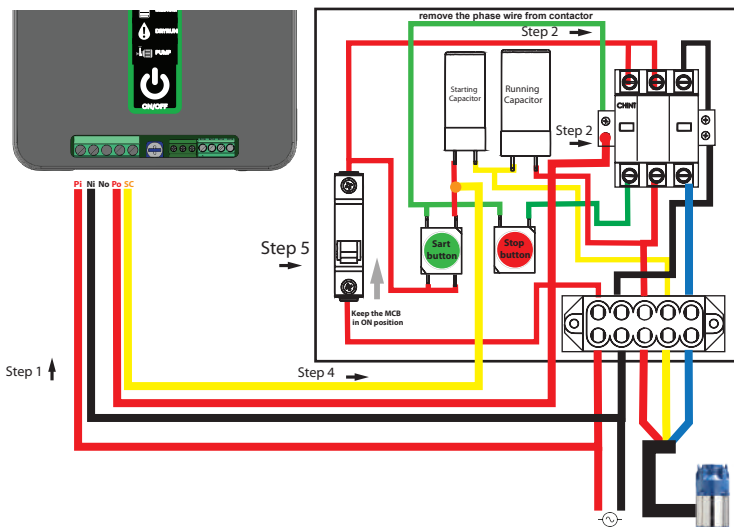

- Step 1 Connect phase & neutral to the Motcon Lite Controller in parallel with phase & neutral of the starter box.
- Step 2 Identify the phase wire of the contactor coil inside the starter panel, disconnect it from the coil terminal, and connect the phase output **Po** of the Motcon Lite Controller to the contactor's phase terminal.
- Step 3 Identify the Starting capacitor wire in "Push ON" Green button of starter panel, using its colour code to the starting capacitor.
- Step 4 Connect the **SC** terminal of Motcon Lite pump controller to the terminal of "ON" green button where the starting capacitor wire is connected.
- Step 5 Keep the MCB in "ON" (up) position always.

Dry Run Time Setting Instructions

The dry run time of your water level controller can be adjusted using the potentiometer. This setting determines how long the motor will run without water before it automatically turns off. Follow these steps to set the dry run time:

1. Turn OFF the Device:

- Ensure the device is powered off using the power switch.

2. Enter Dry Run Time Change Mode:

- Press and hold the ON/OFF pushbutton switch.
- While holding the pushbutton switch, turn the device ON using the power switch.
- Release the pushbutton switch after the device powers on. The controller will now be in dry run time change mode.

3. Select the Desired Dry Run Time:

- Press the pushbutton switch once. The Dry run LED will blink to indicate the current default dry run time setting (e.g., 2 blinks for 2 minutes).
- Rotate the potentiometer to adjust the dry run time.
- Press the pushbutton switch again to confirm the new setting. The Dry run LED will blink to indicate the selected dry run time (e.g., 5 blinks for 5 minutes).

Example:

If you want to set the dry run time to 5 minutes:

- Rotate the potentiometer until the LED blinks 5 times.
- Press the pushbutton switch to confirm the setting.

Summary of LED Blinks for Dry Run Time:

- 2 blinks = 2 minutes
- 5 blinks = 5 minutes
- 8 blinks = 8 minutes
- 10 blinks = 10 minutes
- 12 blinks = 12 minutes
- 15 blinks = 15 minutes
- 18 blinks = 18 minutes
- 20 blinks = 20 minutes

Ensure the LED blinks the correct number of times to confirm the new dry run time setting.

By following these steps, you can easily adjust and confirm the dry run time on your water level controller. This ensures your system operates efficiently and prevents damage due to dry running.

TRANSMITTER DATA SHEET	
Mode of operation	Wireless-LoRa Technology
Frequency	866Mhz
Antenna power	0.5dBi
Sensing material	Magnetic Float Sensors
Sensing parameter	Tank low,Tank full,Dryrun
Adapter input	150-240V,0.12A 50Hz
Adapter output	5V DC - 12V DC
Enclosure material	Polycarbonate
Protection	IP65
Unit dimension	85x60x35
Weight	120gms

RECIEVER DATA SHEET	
Mode of operation	Wireless-LoRa Technology
Frequency	866 Mhz
Control characteristics	Overhead & Sump Tank
Control method	Manual/ Auto
Rated output power	0.37.KW - 1.86KW(0.5HP-2.5HP)
Rated input power	AC 230V/50Hz Single phase
Trip response time of Dry run	10 sec
Output Load	All single phase panels
Protection functions	Dry run
	Transient surge
Unit dimention	105x85x35 mm
Weight	175 gms



85mm

Wall Mounting Reference Holes

